

STRAPS SHEAR TESTER

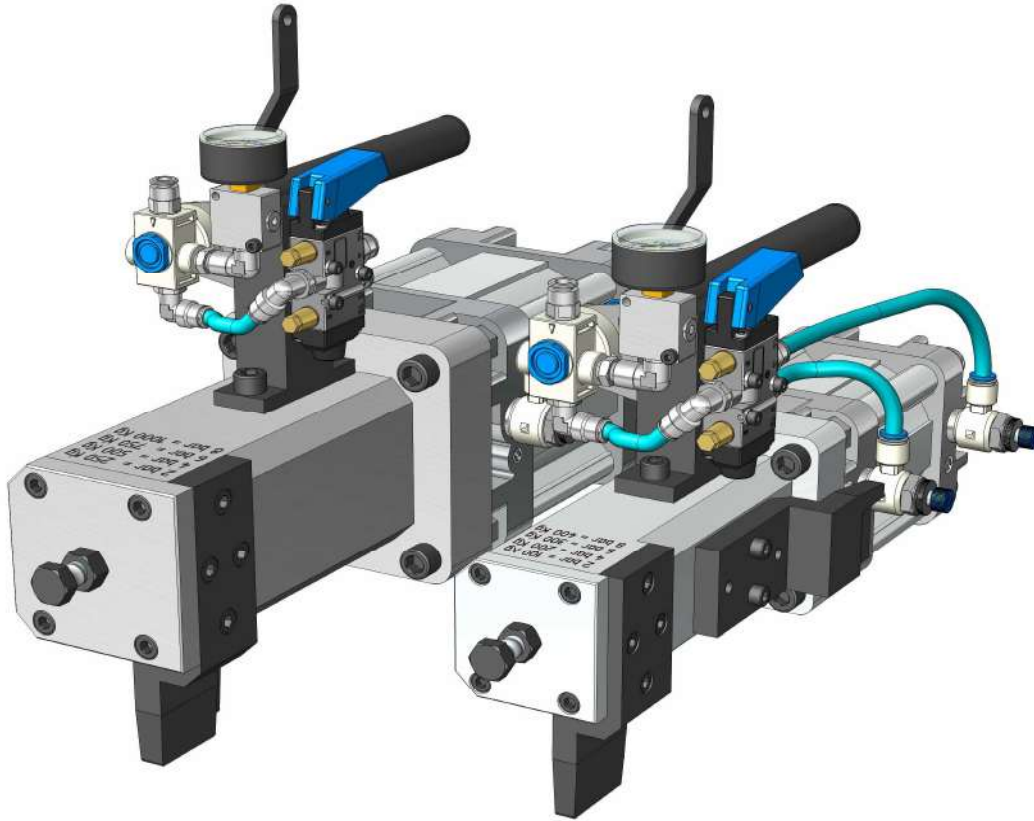

- Manual device to test the quality of the straps welding.
- Adjustable stroke.
- Adjustable speed.
- Cutting force adjustable by an air pressure regulator with manometer.
- Custom clamps.
- Two versions available.

"Type PCM"



Dimensions: mm 400 x 100 x 300 H

Weight: ~ 8,5 Kg

Compressed Air: 1 ÷ 8 bar

Force: 0 ÷ 400 Kg

Suitable for car batteries (\varnothing welding \leq 11mm)

"Type PCMP"



Dimensions: mm 470 x 140 x 370 H

Weight: ~ 18 Kg

Compressed Air: 1 ÷ 8 bar

Force: 0 ÷ 1000 Kg

Suitable for car batteries (\varnothing welding $>$ 11mm)

By customizing the clamps you can test connections of different shapes and sizes.

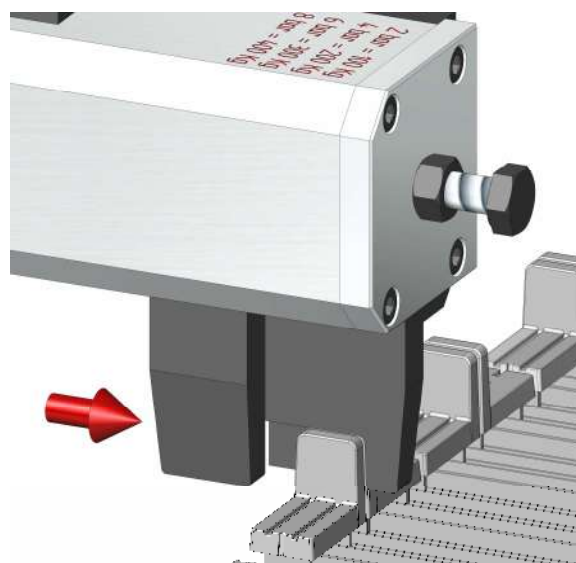
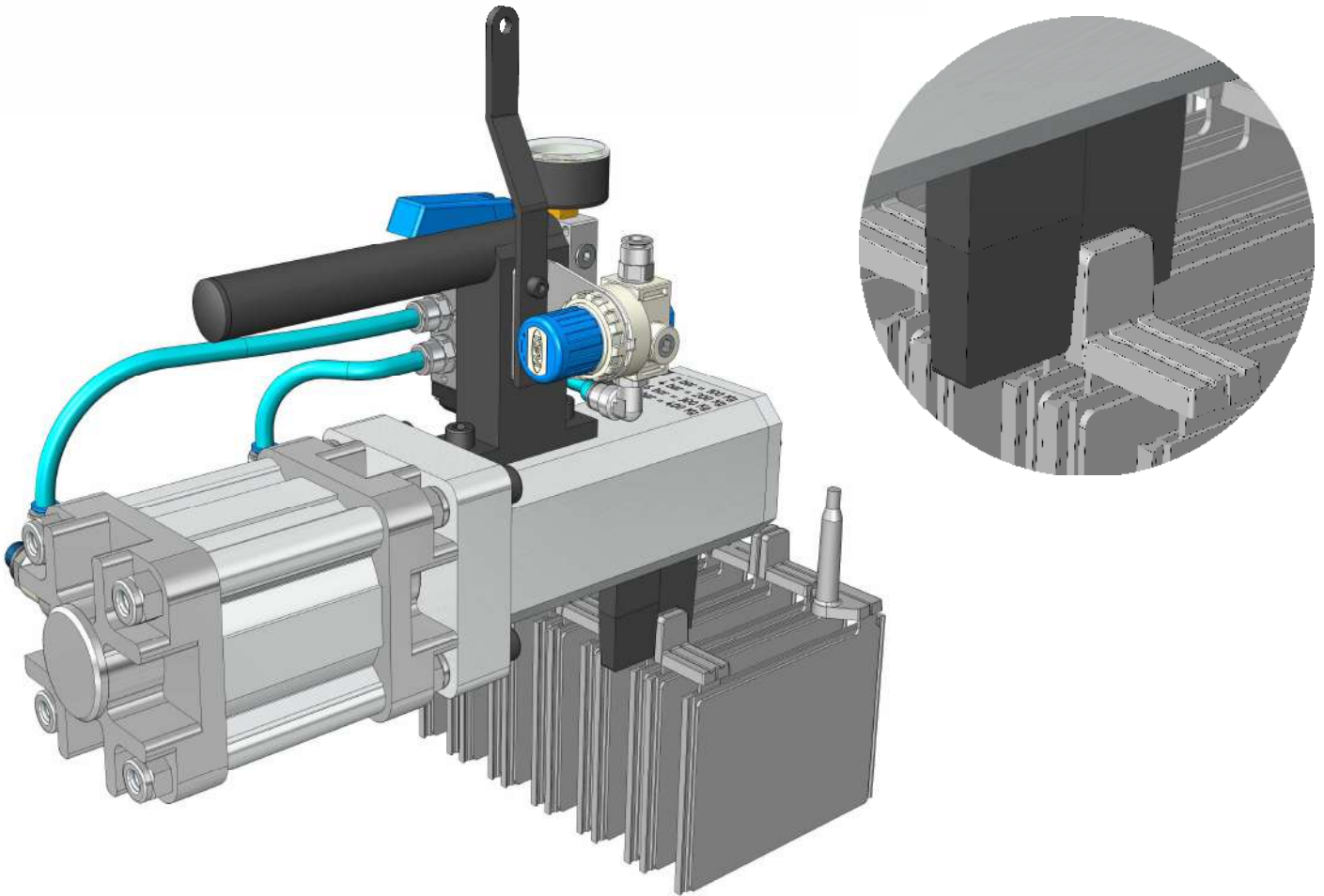

WE RESERVE ANY POSSIBLE MODIFICATIONS